

SMEC

SL 3500 series

BOX GUIDE HORIZONTAL TURNING CENTER



- 1988 - Started as Samsung Heavy Industries Machine Tools Business
- 1989 - Horizontal and vertical machining center technology partnership with OKK Japan
- 1991 - Turning center and vertical machining center technology partnership with Mori Seiki
- 1996 - 5-sided processing center technology partnership with Toshiba
- 1999 - Spun out from Samsung Aerospace Industries and established SMEC Co., Ltd

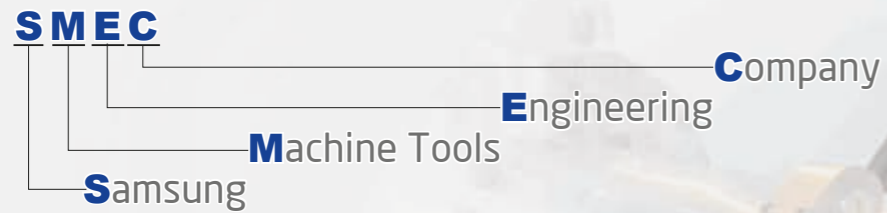

SL 3500/3500L
 A Type : 12" / B Type : 15"

SL 3500M/3500LM
 A Type : 12" / B Type : 15"

Strongest in class with superb structural design
 Simultaneous heavy duty and precision turning

- 45 degree torque tube type bed to support heavy duty turning
- Significantly reduced non-cutting time and efficient turning
- Low-center of gravity reducing vibration, thermal deformation and improving rigidity

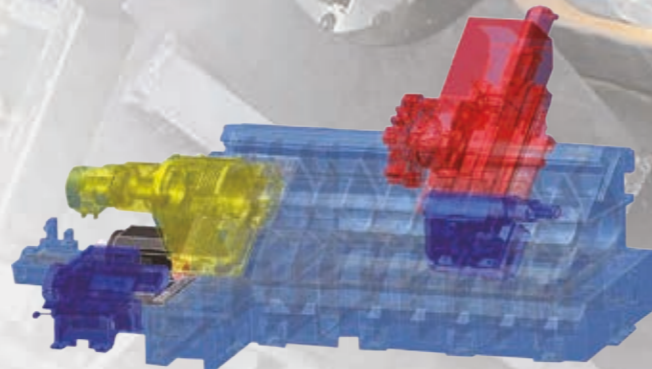

High Accuracy, High Rigidity Spindle

Pin Tube Rib Design for Minimal Axis Heat Transfer

Radiator fan-like pin tube rib design dissipates heat, maintaining minimal thermal expansion.

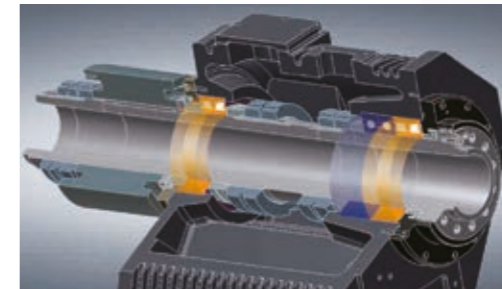

Output Converting Transmission



Equipped as standard feature, high Output Converting Transmission provides heavy-duty machining.



Spindle Power & Torque Diagram

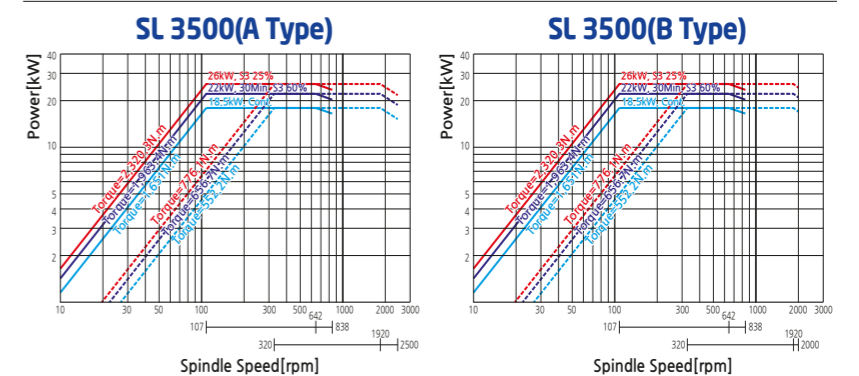

SL 3500 series a compact, ultra precision Turning Center, combined with SMEC's advanced technological features.

Spindle speed
2,500 rpm (A Type 12")
2,000 rpm (B Type 15")

Spindle motor(cont/max.)
18.5/26 kW

Rapid traverse(X/Z)
12/15 m/min (SL 3500/L)
20/24 m/min (SL 3500M/LM)

Feed motor(X/Z)
3/4 kW (SL 3500/L)
4/7 kW (SL 3500M/LM)

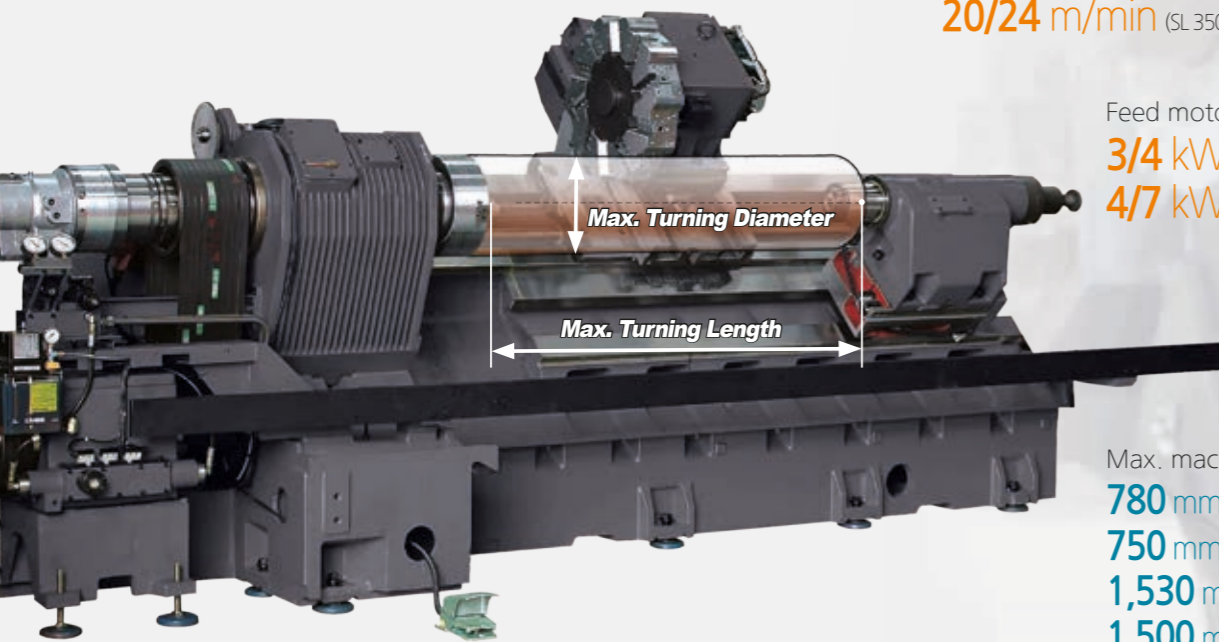

Max. machining length
780 mm (SL 3500A/B)
750 mm (SL 3500AM/BM)
1,530 mm (SL 3500AL/BL)
1,500 mm (SL 3500ALM/BLM)

Max. machining diameter
500 mm

Highly Reliable and Rigid Structural Design

- One piece Meehanite casting with heavily ribbed torque tube design
- Rigid bed supports for powerful cutting
- Excellent vibration dampening and thermal displacement design

SL 3500/L (High Speed Hydraulic Turret)

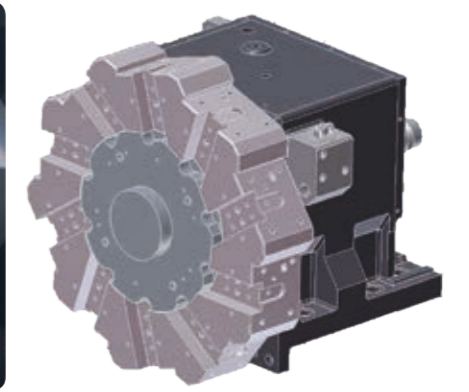

Indexing Time Number of tool positions
0.25 sec **10 stations (Opt. : 12 stations)**

High Speed, Heavy Duty Hyd. Index Turret

Driven by a high torque hydraulic index motor, the 10-station heavy-duty turret can accept tools on both left and right side of each station. Turret indexing (repeatability ± 0.005) is non-stop, bi-directional with a fast 0.25 second next station index time. A large diameter (Ø250) Curvic coupling with 6,377kgf clamping force enables precision as well as heavy-duty cutting.

SL 3500M/LM (BMT High Speed Turret)

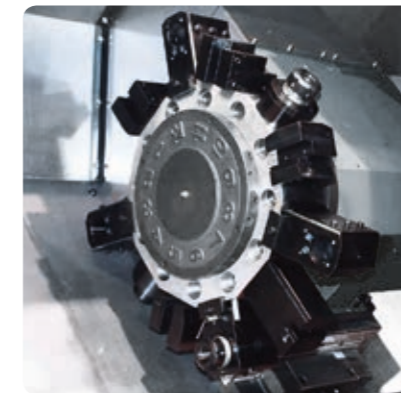

Turret Torque Diagram

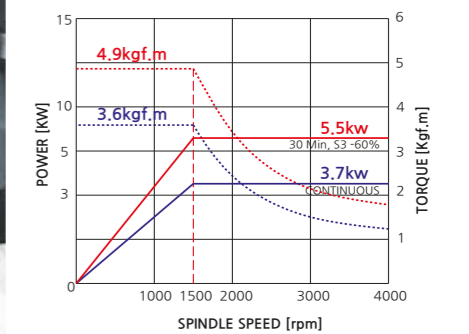

Indexing Time Number of tool positions Milling Spindle Speed Tool Holder
0.25 sec **12 stations** **4,500 rpm** **BMT 65**

BMT Milling Turret (M Type)

SL 3500M/LM is equipped with standard 12-station BMT turret capable of accepting rotary tools at any station, providing flexible machining thru various machining operations in just one set-up. Each BMT holder is securely tightened by 4 screws, allowing the turret to perform heavy-duty cutting, milling and drilling operations. Turret indexing is non-stop, bi-directional with a fast 0.25second next station index time.



Centralized Operation Panel

The centralized operation panel with its 10.4 inch color TFT LCD monitor is able to swivel 90 degrees, providing operators with easy access to the control panel while working on the machine.



Rigid 45 degree Slant Bed

45 degree slant torque tube design bed and wide guide slide way ensure long term rigidity and machining accuracy.

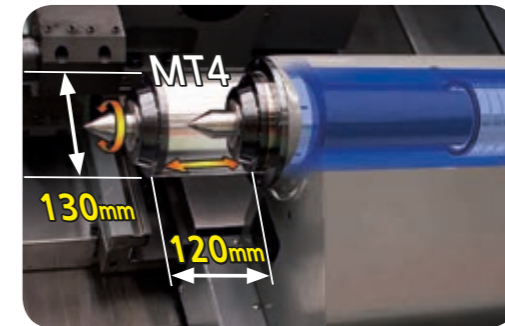
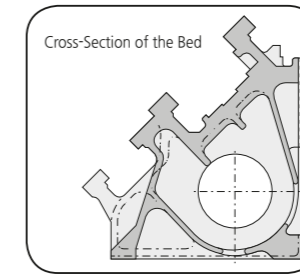

Programmable Tailstock(Carriage direct-coupled) [Std.]

The programmable tailstock body mounted is on wide guide ways to ensure rigid work piece support.

Pre-tensioned and Double Anchored Ballscrews

All axes ballscrews are pre-tensioned, heat treated and fixed by double anchors on both ends, providing ultimate rigidity and minimal thermal growth.

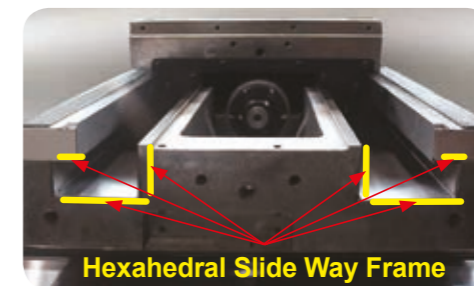
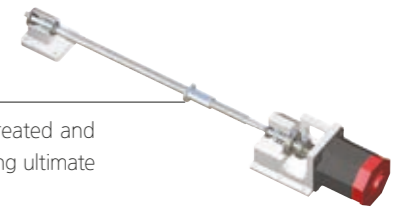

Hexahedral Slide Way Frame (X-axis)

Wide integral way is machined from the casting, induction hardened and precision ground to ensure long-term rigidity, machining accuracy and heavy-duty machining.

High Precision

표면조도

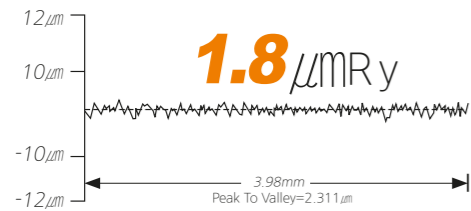

Model : SL 3500

진원도

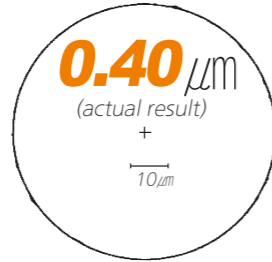

Cutting condition	
Tool	Diamond tool <nose radius 0.020 inch>
Material	AL150<Aluminum>
Cutting speed	230 m/min
Feedrate	0.05 mm/rev
Depth of cut	0.1 mm
Outer diameter	200 mm
Filter	1-50

Processing Speed

Turning Performance (material:SM45C) SL 3500L

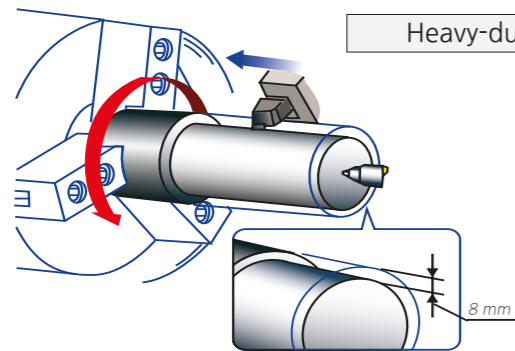

Spindle speed
370 rpm
Cutting speed
150 m/min
Depth of cut
8 mm <Spindle Load 50%>
Feedrate
0.4 mm/rev

Standard Accessories

Optional Accessories



Automatic Lubricator



Auto Door



Tool Presetter

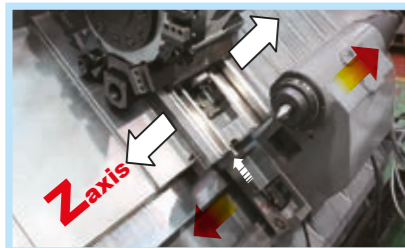

Programmable Tailstock



Chip Conveyor

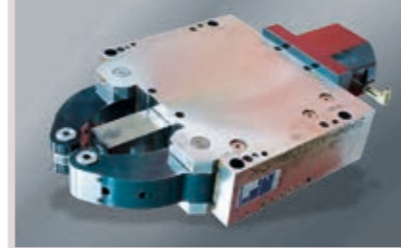

Steady Rest

Tooling System

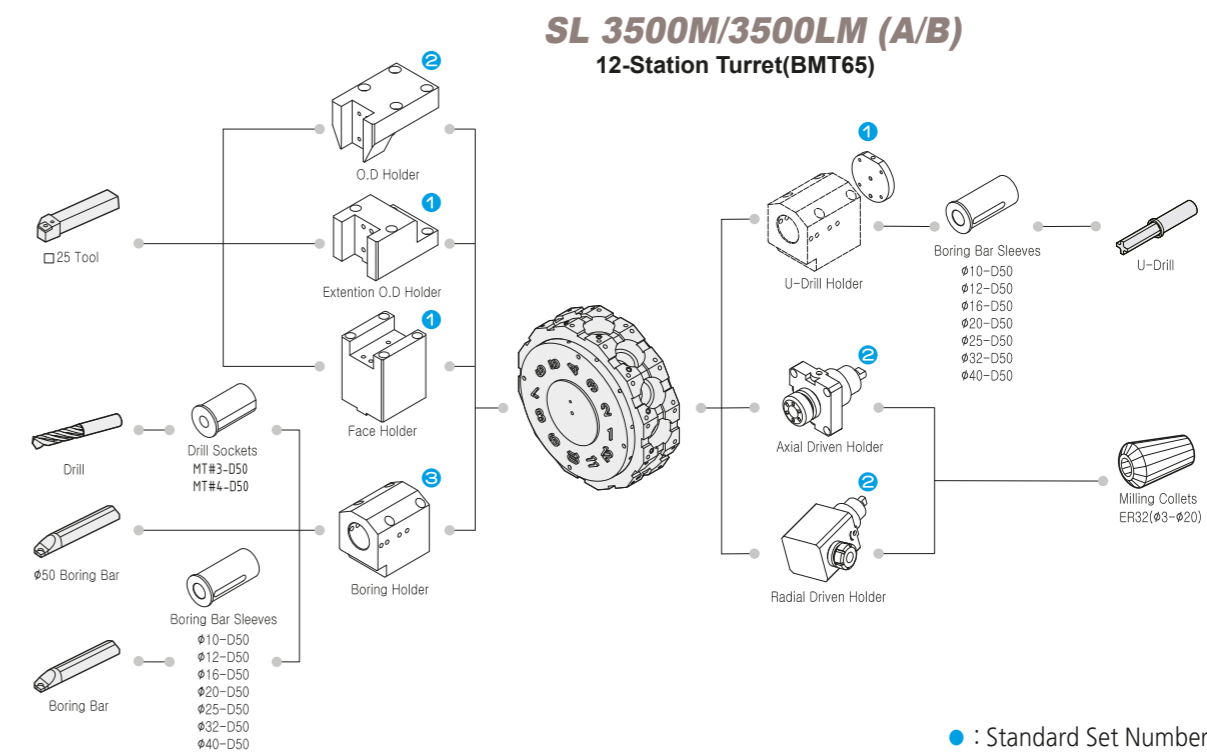
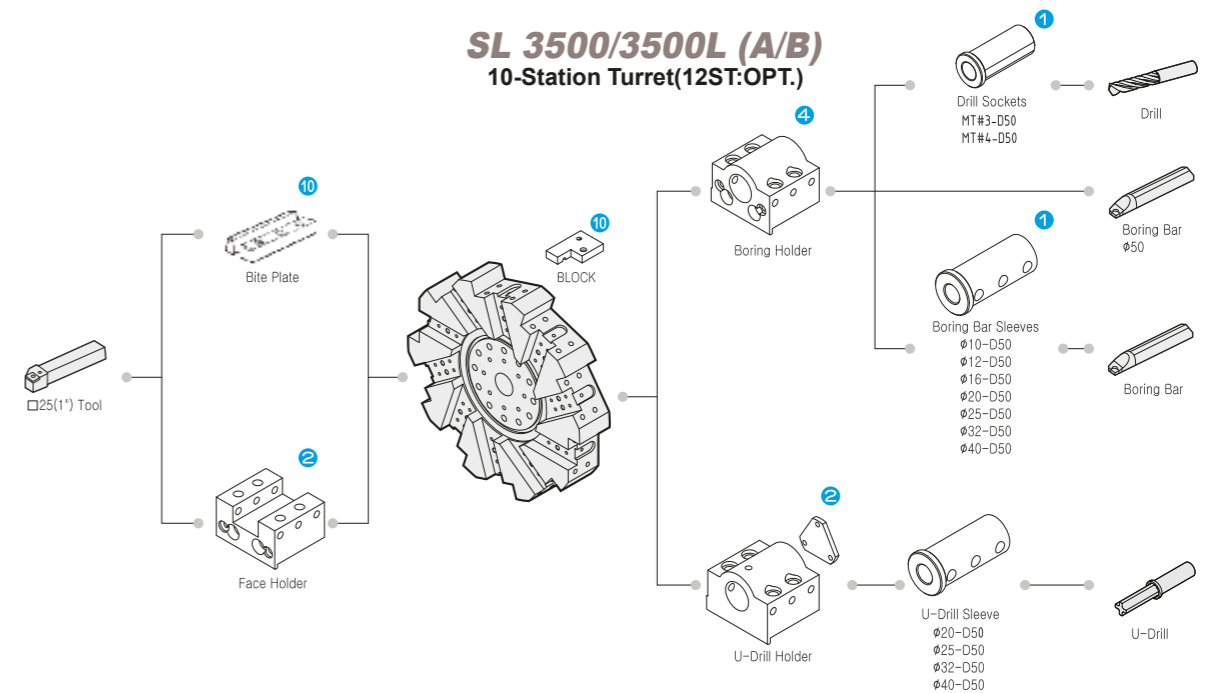

● : Standard Set Numbers

Work Range

Unit : mm

SL 3500 / 3500L

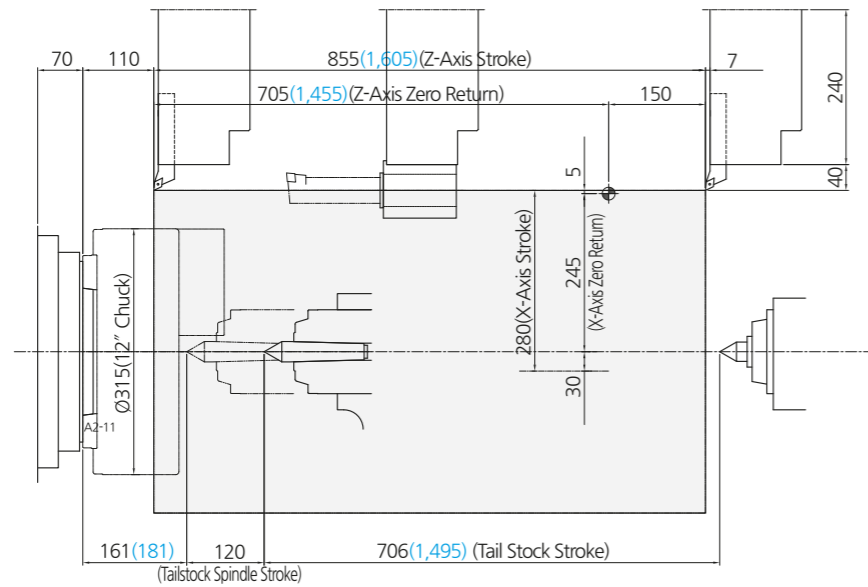

SL 3500M / 3500LM

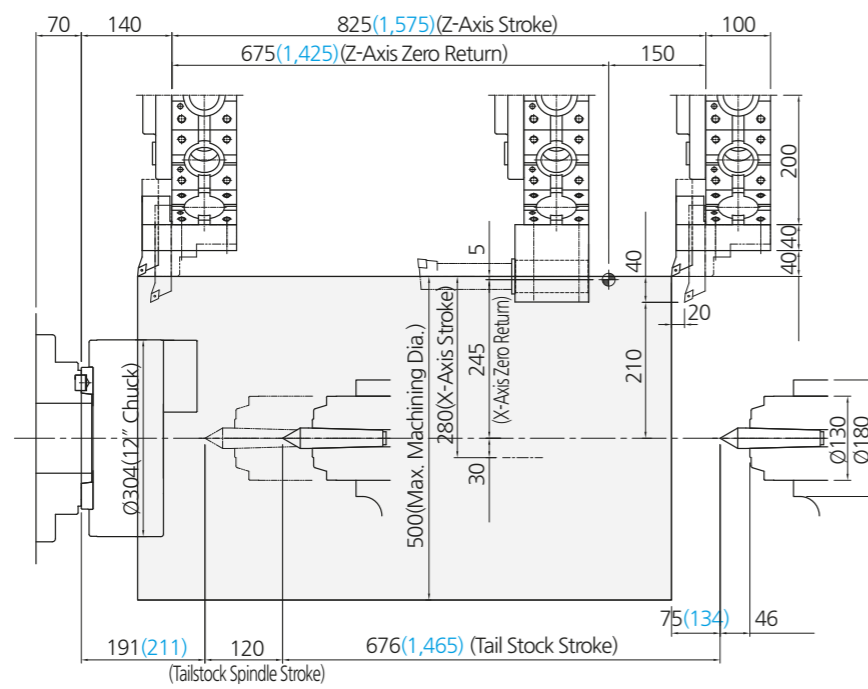

Turret Head Interference

Unit : mm

STD Turret

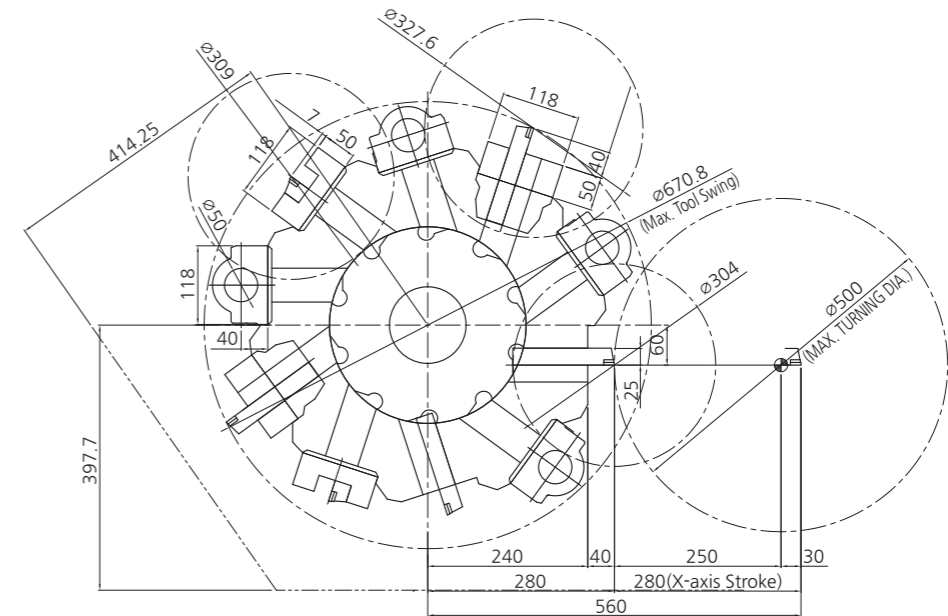

Mill Turret (BMT 65)

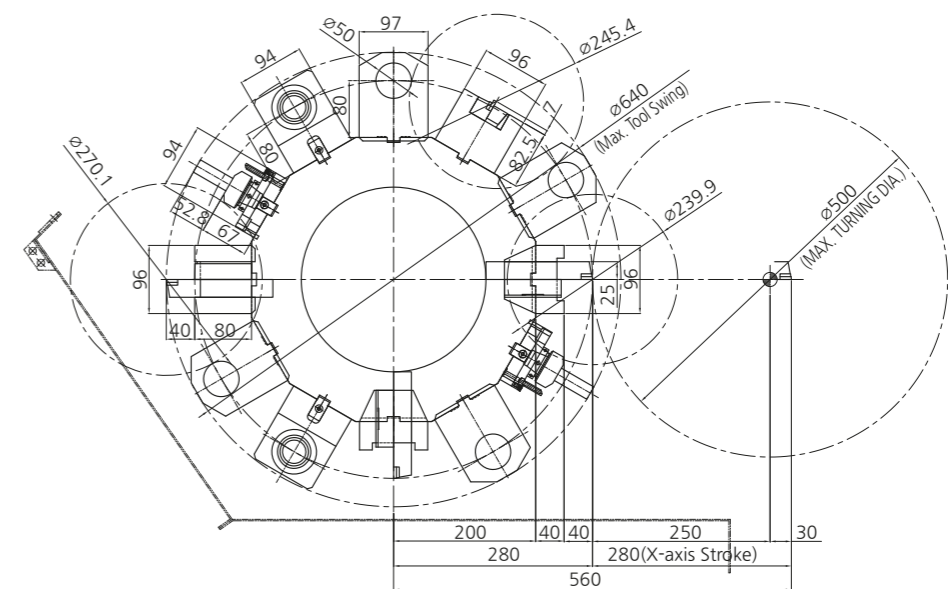

Machine Dimensions

Unit : mm

SL 3500 / 3500M

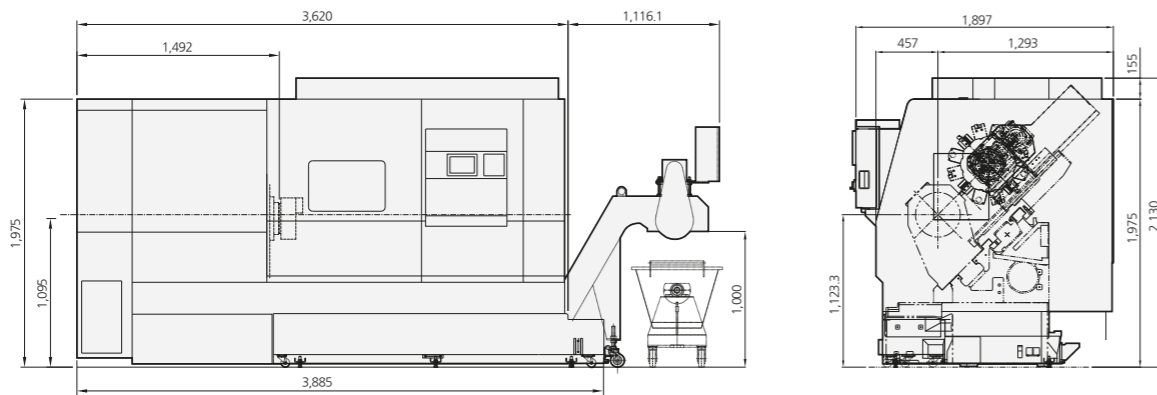

SL 3500L / 3500LM

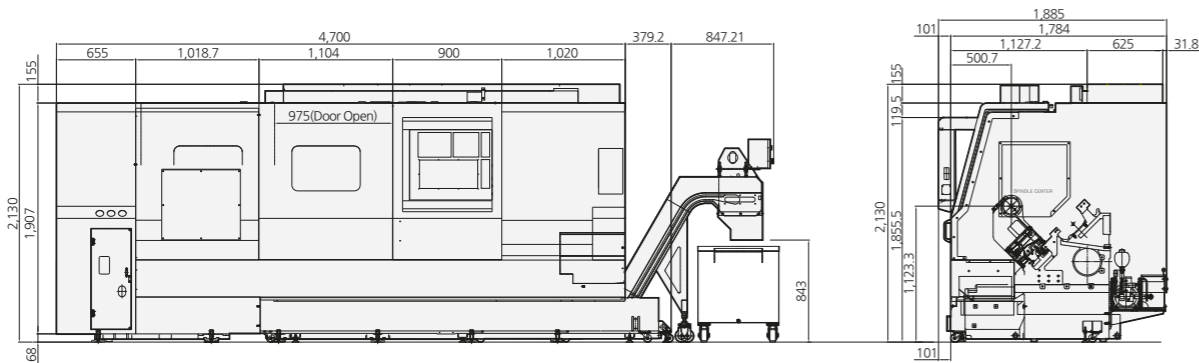

Standard Accessories

- 12" hollow 3 jaws chuck (A Type)
- 15" hollow 3 jaws chuck (B Type)
- Chuck clamp confirmation
- Chuck clamp foot switch
- Chuck pressure switch
- Coolant system
- Door interlock
- Full splash guard with coolant tank
- Jaw (soft 3set, hard 1set)
- Leveling unit
- Manual/Part list (1set)
- Patrol lamp (3 colors)
- Safety precaution name plate
- Spindle orientation
- Tailstock (programmable)
- Tool box
- Tool holders
- Work light (LED lamp)

Optional Accessories

- Air blower
- Air conditioners (electric cabinet)
- Air gun
- Auto door
- Bar Feeder Interface
- Chip bucket
- Chip conveyor
- Coolant blower
- Coolant chiller
- Coolant gun
- Coolant level switch
- Counter (total, multi, tool, work)
- Dual pressure chucking
- Oil mist collector
- Oil skimmer
- Part catcher
- Robot interface
- Special chuck
- Steady rest
- Tool presetter (manual/auto)
- Transformer

Major Specifications

[] : Option

DESCRIPTION	SL 3500		SL 3500M			
	A type	B type	A type	B type		
Chuck	Chuck size	inch	12"	15"	12"	15"
Capacity	Swing over bed	mm	680	680	680	680
	Swing over cross slide	mm	505	505	505	505
	Max. turning diameter	mm	500	500	500	500
	Max. milling diameter	mm	-	-	526	526
Spindle	Max. machining length	mm	780	780	750	750
	Spindle speed	rpm	2,500	2,000	2,500	2,000
	Spindle nose	ASA	A2-11	A2-11	A2-11	A2-11
	Draw tube ID	mm	103	117.5	103	117.5
Turret	Spindle bore diameter	mm	115	132	115	132
	Spindle motor (Cont./Max)	kW	18.5/26	18.5/26	18.5/26	18.5/26
Travels	X-axis travel	mm	280	280	280	280
	Z-axis travel	mm	855	855	825	825
	X-axis Rapid traverse rate	m/min	12	12	20	20
	Z-axis Rapid traverse rate	m/min	15	15	24	24
Tailstock	Number of tool stations	ea	10[12]	10[12]	12 (BMT65)	12 (BMT65)
	Turning tool shank size	mm	25	25	25	25
	Boring bar diameter	mm	50	50	50	50
	Turret index time(next station swivel time)	sec	0.25	0.25	0.25	0.25
	Rotary tool speed	rpm	-	-	4,500	4,500
	Rotary tool motor (Cont./Max)	kW	-	-	3.7/5.5	3.7/5.5
Machine	Quill diameter	mm	130	130	130	130
	Quill stroke	mm	120	120	120	120
	Spindle taper	MT	MT4 (Built-in)	MT4 (Built-in)	MT4 (Built-in)	MT4 (Built-in)
Machine	Size (with Side Chip conveyor) LxWxH	mm	3,885(4,736) × 1,897 × 2,130		3,885(4,736) × 1,897 × 2,130	
	Size (with Rear Chip conveyor) LxWxH	mm	-		-	
	weight	kg	8,300	8,300	8,300	8,300
	Coolant tank capacity	Liter	234	234	234	234
ELECTRIC POWER SUPPLY	kVA/V	42/220	36/220	57/220	57/220	
CONTROLLER		FANUC, SIEMENS				

※Figures in inches are converted from metric measurements.

Major Specifications

[] : Option

DESCRIPTION			SL 3500L		SL 3500LM	
			A type	B type	A type	B type
Chuck	Chuck size	inch	12"	15"	12"	15"
	Swing over bed	mm	680	680	680	680
Capacity	Swing over cross slide	mm	505	505	505	505
	Max. turning diameter	mm	500	500	500	500
	Max. milling diameter	mm	-	-	526	526
	Max. machining length	mm	1,530	1,530	1,500	1,500
	Spindle speed	rpm	2,500	2,000	2,500	2,000
Spindle	Spindle nose	ASA	A2-11	A2-11	A2-11	A2-11
	Draw tube ID	mm	103	117.5	103	117.5
	Spindle bore diameter	mm	115	132	115	132
	Spindle motor (Cont./Max)	kW	18.5/26	18.5/26	18.5/26	18.5/26
Travels	X-axis travel	mm	280	280	280	280
	Z-axis travel	mm	1,605	1,605	1,575	1,575
	X-axis Rapid traverse rate	m/min	12	12	20	20
	Z-axis Rapid traverse rate	m/min	15	15	24	24
Turret	Number of tool stations	ea	10[12]	10[12]	12 (BMT65)	12 (BMT65)
	Turning tool shank size	mm	25	25	25	25
	Boring bar diameter	mm	50	50	50	50
	Turret index time(next station swivel time)	sec	0.25	0.25	0.25	0.25
	Rotary tool speed	rpm	-	-	4,500	4,500
	Rotary tool motor (Cont./Max)	kW	-	-	3.7/5.5	3.7/5.5
Tailstock	Quill diameter	mm	130	130	130	130
	Quill stroke	mm	120	120	120	120
	Spindle taper	MT	MT4 (Built-in)	MT4 (Built-in)	MT4 (Built-in)	MT4 (Built-in)
Machine	Size (with Side Chip conveyor) L×W×H	mm	5,079(5,926) × 1,885 × 2,130		5,079(5,926) × 1,885 × 2,130	
	Size (with Rear Chip conveyor) L×W×H	mm	-		-	
	weight	kg	9,300	9,300	9,300	9,300
	Coolant tank capacity	Liter	300	300	300	300
ELECTRIC POWER SUPPLY	kVA/V	42/220	36/220	57/220	57/220	
CONTROLLER		FANUC, SIEMENS				

※Figures in inches are converted from metric measurements.

NC Specifications / FANUC Series

	Item	Specification	FANUC Series
Controlled axis	Max. feed axes		4 AXIS
	Feed axes		X/Z/(Cs)
	Max. simultaneously controlled axis		4
Operation functions	Least command increment	0.001mm / 0.0001"	○
	Pulse handle feed	X1, X10, X100	○
	Feedrate per minute	G98	○
Interpolation functions	Feedrate per revolution	G99	○
	Linear interpolation	G01	○
	Circular interpolation	G02, G03	○
	Dwell	G04	○
	Polar coordinate interpolation	G12.1, G13.1	○
	Cylindrical interpolation	G70.1	○
	Variable lead thread cutting	G34	○
	Continuous threading		○
	Reference position return	G28	○
Reference position return check	G27	○	
Feed function	Rapid traverse rate override	F0, 25%, 50%, 100%	○
	Feedrate override		0~150%
Spindle function	Spindle orientation		○
	Rigid tapping		○
Tool functions	Tool number command	T4-Digt / T2-Digt	T4-Digt
	Tool nose radius compensation	G40 ~ G42	○
	Tool offset pairs		○
	Tool geometry/wear offset	GEOMETRY & WEAR DATA	○
	Tool life management		○
	Tool path graphic display		○
	Automatic tool offset	G36, G37	○
Program input	Direct input of tool offset value measured B		○
	Absolute/incremental programming		○
	Multiple repetitive cycle	G70 ~ G76	○
	Canned cycles	G90, G92, G94	○
	Inch/metric conversion	G20 / G21	○
	Program restart		○
	Retraction for rigid tapping		○
	Max. programmable dimension	±99999.999mm/±9999.9999"	○
	M function	M3 digit	○
	Custom macro		○
	Canned cycle for drilling		○
	Direct drawing dimension programming		○
	Programmable data input	G10	○
Optional block skip		○	
Workpiece coordinate system	G52 ~ G59	○	
Number of registerable programs		400EA	
Setting and display	Alarm & Operator history display	ALARM & OPERATION DISPLAY	○
	Run hour and parts count display	RUNNING TIME & PART NO. DISPLAY	○
	Display spindle & servo overload	SPINDLE & SERVO LOAD DISPLAY	○
	Self-diagnosis function		○
	Extended part program editing	COPY,MOVE, CHANGE OF NC PROGRAM	○
Display screen		10.4" color	
Data input/output	Memory card input/output		○
	USB memory input/output		○
Editing operation	Part program storage size	512Kbyte(1280m)	○
Manual guide i	Manual Guide i		○



Fanuc Manual Guide i

Erstellen Sie Ihre Teileprogramme in nur wenigen Schritten

Reduzieren Sie den Zeitaufwand bei der Überführung Ihrer Zeichnungen in die Produktion:
Mit dem FANUC MANUAL GUIDE i lassen sich sowohl einfache als auch hoch komplizierte Maschinenzyklen inklusive Dreh-, Fräs-, Bohr- und Messzyklen schnell und einfach umsetzen. Dabei unterstützt die Software Sie durch intuitive interaktive Benutzerführung sowie spezielle Funktionen zur einfachen Teileprogrammierung und Simulation.

Merkmale:

- Bedienerfreundliche Programmierumgebung
- Erweiterte Zyklusbearbeitung (Drehen und Schleifen)
- Leistungsstarke Profilberechnung
- Nahtloser Umgebungswechsel
- Werkzeugverwaltungsfunktion
- Messzyklen
- Restschnitt
- Bearbeitungssimulationen

Die benutzerfreundliche Software MANUAL GUIDE i zur Fertigungsprogrammierung vereinfacht den Betrieb Ihrer Maschine. Die innovative Programmierung ermöglicht die Entwicklung von der Zeichnung zum Werkstück in kürzester Zeit. Dank MANUAL GUIDE i die CNC-Maschinen von FANUC schnell und einfach für Dreh-, Schleif- und Verbundbearbeitungsprozesse programmiert werden.

Selbsterklärende Menüs und grafische Simulationen führen den Benutzer durch die Programmierung, was selbst bei komplexen Bearbeitungsvorgängen zu hocheffizienten Ergebnissen führt.



Siemens Sinumerik 828D

Mehr Produktivität mit SINUMERIK 828D
– Smart Operation

Robuste MultiTouch-Bedienung
kombiniert mit SideScreen

Für Werkstatt, Lohnfertigung und Großserienfertigung sind hochproduktive Automatisierungslösungen gefragt, die den Weg in die Digitalisierung begleiten.

Ob Einzelteil- oder Massenfertigung, einfache oder komplexe Werkstücke – die SINUMERIK CNC-Lösungen bieten Werkzeugmaschinenbetreibern immer die passende Lösung für ihre Anforderungen.

Durch die tägliche Nutzung von mobilen Geräten wie Smartphones, Tablets oder Computern haben wir eine bestimmte Art der Interaktion mit Maschinen entwickelt. Werkzeugmaschinen bilden hier keine Ausnahme mehr.

- Der Trend zu größeren Bildschirmen eröffnet die Möglichkeit, zusätzliche anpassbare Fenster in das HMI einzubinden.
- Änderung des Bildseitenverhältnis von 4:3 in 16:9.
- Zugleich stehen Lösungen bereit, mit denen die Benutzeroberfläche individuell an die Anforderungen der Kunden angepasst werden kann.
- So kann der Maschinenbediener wesentlich mehr Informationen parallel betrachten.

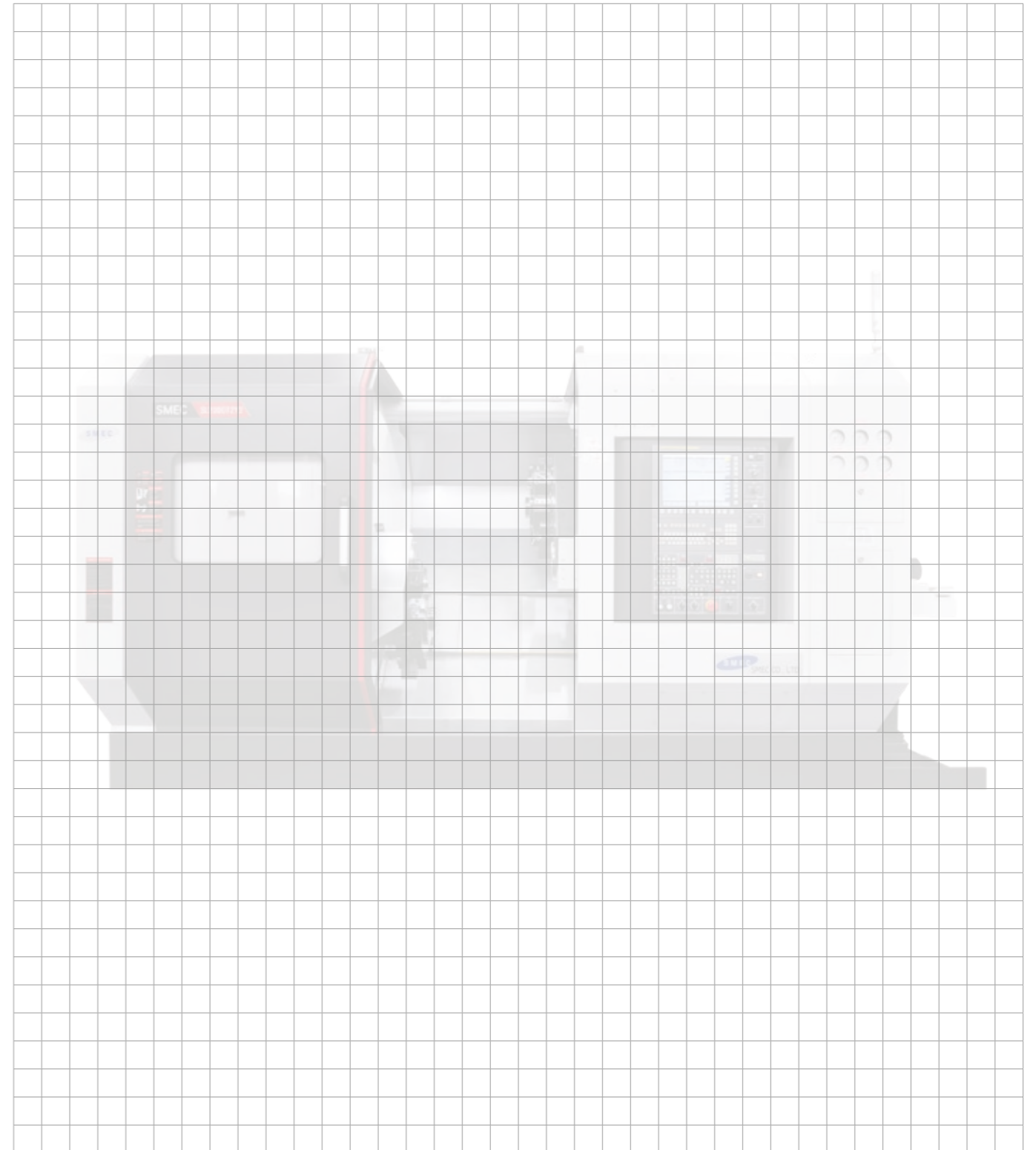
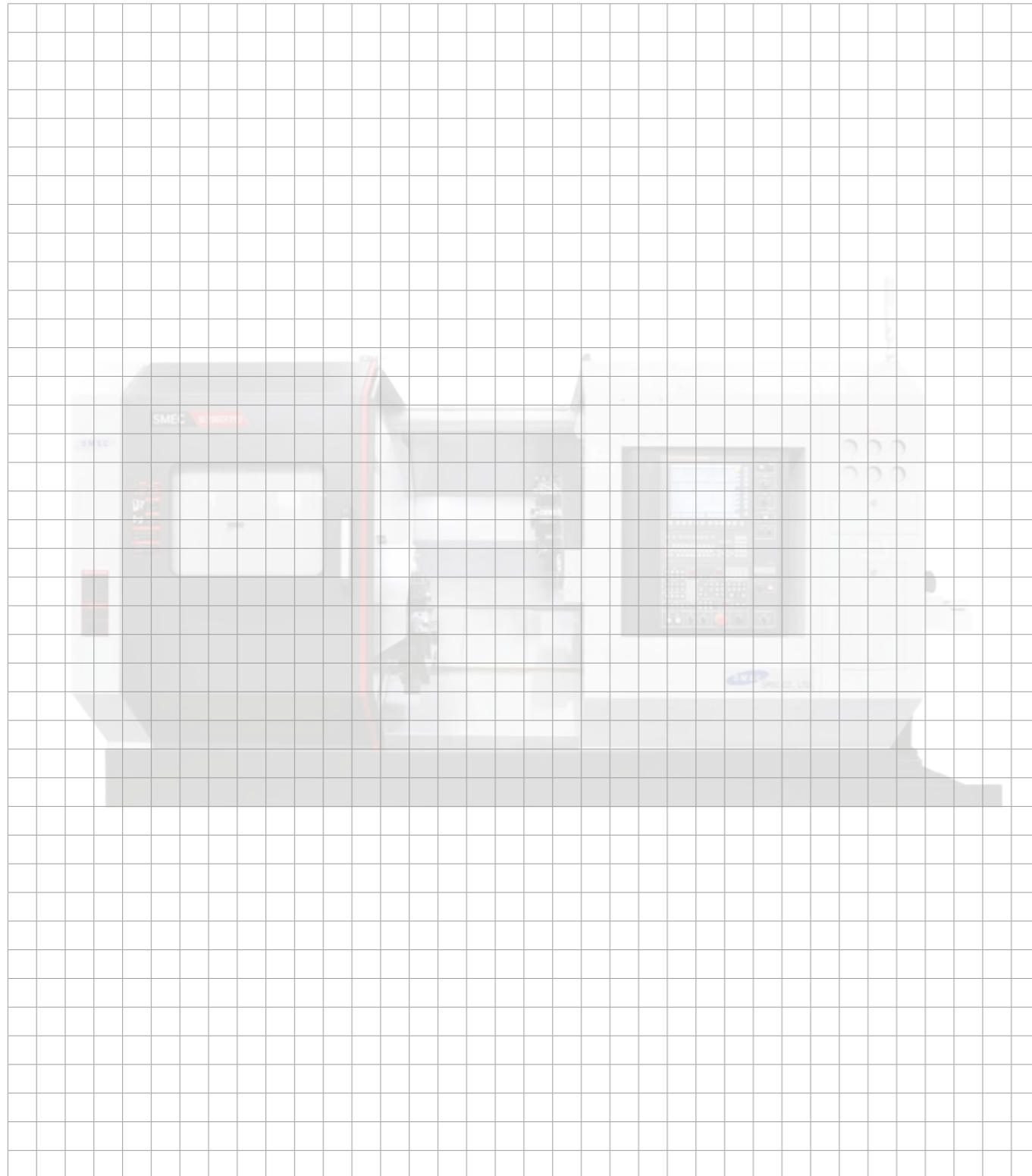

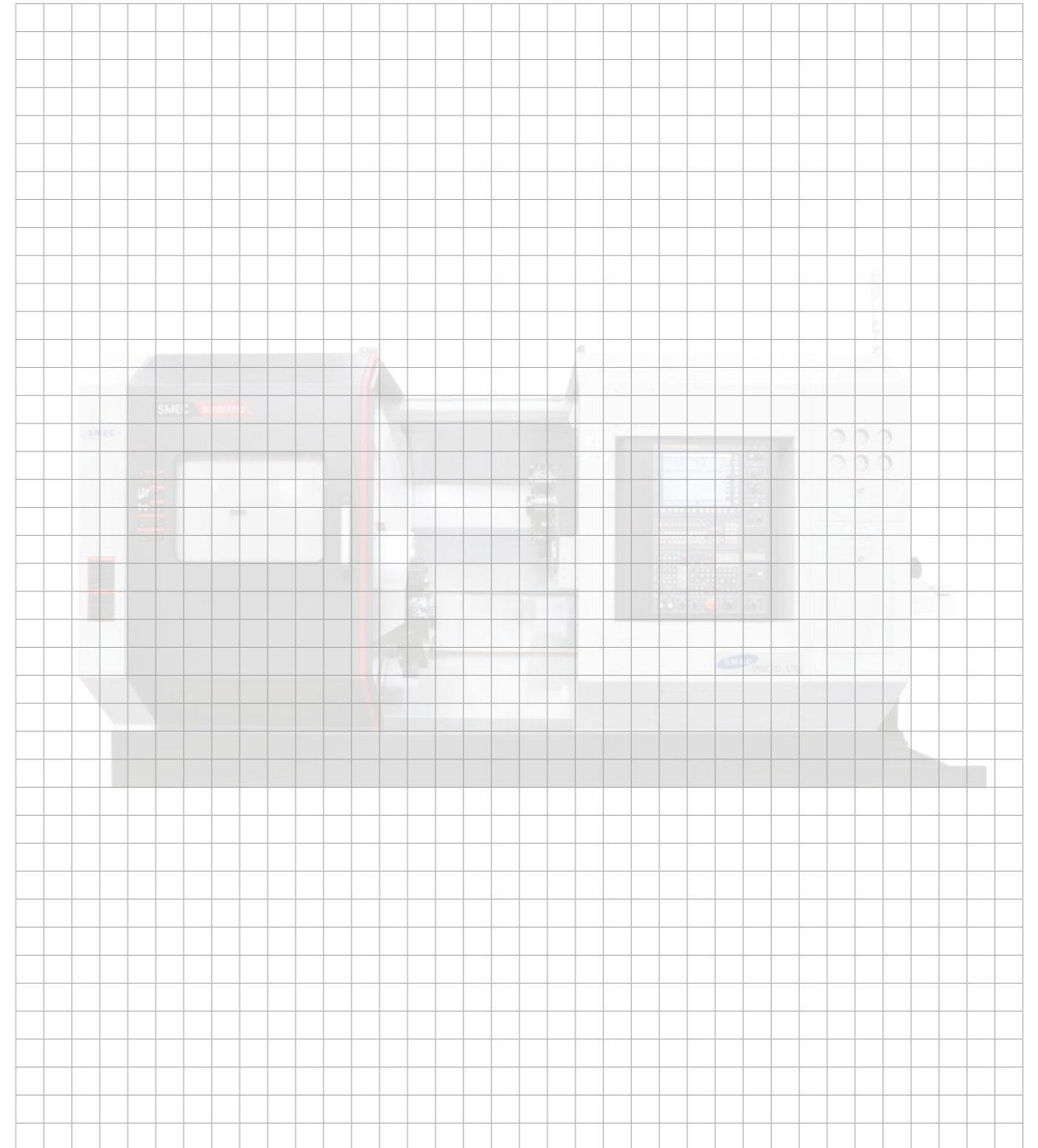
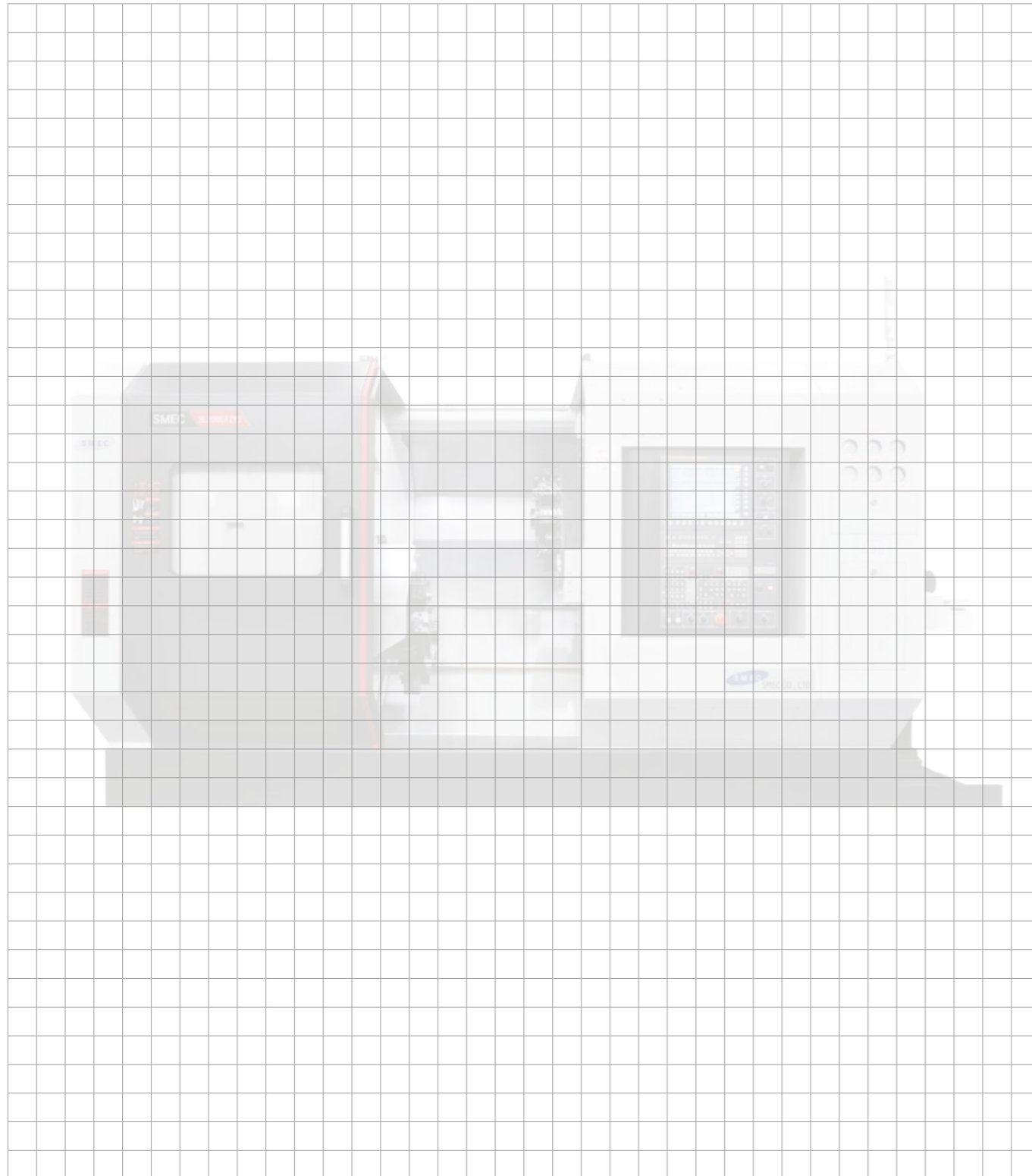

Gleich einspeichern und
ANGEBOT sichern!

Tel. 49 (0) 9672 92415-730

Ihr Partner in
**Deutschland
& Österreich**



Industriestraße 6c
92431 Neunburg v.Wald

Servicehotline
+49 (0) 9672 92415-790

info@wsf-wzm.de
www.wsf-wzm.de